

Castleforms ICF Therm Wall System

NSAI Agrément (Irish Agrément Board) is designated by Government to issue European Technical Approvals.

NSAI Agrément Certificates establish proof that the certified products are **'proper materials'** suitable for their intended use under Irish site conditions, and in accordance with TGD Part D of the second schedule of the **Building Regulations 1997 and subsequent revisions**.



SCOPE

This Certificate relates to the Castleforms ICF (Insulated Concrete Formwork) Therm Wall System. Castleforms ICF Therm consists of interlocking modular blocks moulded from fire retardant polystyrene beads into which ready-mix concrete is poured. Each block (form) consists of panels formed from EPS and plastic connectors (webs) made of polypropylene spaced 200mm apart vertically, which are moulded into the EPS during the manufacturing process. An external render system approved by NSAI Agrément for use onto EPS for new build that meets the requirements of Section 3 and 4 of this Certificate is applied to the external face of the Castleforms ICF Therm as the external finish. Plasterboard slabs are screw-fixed to the polypropylene connectors as an internal finish.

Castleforms ICF Therm is certified for use in the construction of buildings of up to five storeys (maximum 15m) in height to the top storey in purpose groups 1(a), 1(b) and 1(d) as defined in TGD to Part B Volume 2 of the Building Regulations, and for use up to six storeys (maximum 18m) in height to the top storey in purpose groups 1(c), 2(a), 2(b), 3, 4(a) and 5 as

defined in TGD to Part B of the Building Regulations.

The system has been assessed for use as load bearing and non-load bearing walls in the buildings purpose groups as stated above. Fire and sound rated walls may be constructed using the system.

DESIGN

The developer is responsible for the overall building design and compliance with Building Regulations.

The Castleforms ICF Therm is intended for use where the architectural and fire strategy drawings are available and satisfy the Building Regulations.

In the opinion of NSAI, the Castleforms ICF Therm Wall System, as described in this Certificate, complies with the requirements of the Building Regulations.



**DEVELOPMENT, MANUFACTURE AND
MARKETING:**

The Castleforms ICF (Insulated Concrete Formwork)
Therm Wall System is developed, manufactured,
and marketed by:

Castleforms Ltd.,
Clonminam Business Park,
Portlaoise,
Laois
R32 DP27
T: 057 868 0684
E: info@castleforms.com
W: www.castleforms.com

1.1 BUILDING REGULATIONS***Part D – Materials and Workmanship*****D1 – Materials & Workmanship****D3 – Proper Materials**

The Castleforms ICF Therm Wall System is comprised of 'proper materials' i.e., materials which are fit for their intended use and for the conditions in which they are to be used.

Buildings incorporating the Castleforms ICF Therm Wall System can be designed to meet the requirements of the following clauses of the Building Regulations:

Part A - Structure**A1 – Loading****A2 – Ground Movement****A3 – Disproportionate Collapse*****Part B – Fire Safety*****B1 & B6 – Means of Escape in Case of Fire****B2 & B7 – Internal Fire Spread (Linings)****B3 & B8 – Internal Fire Spread (Structure)****B4 & B9 – External Fire Spread*****Part C – Site Preparation and Resistance to Moisture*****C3 – Dangerous Substances****C4 – Resistance to Weather and Ground*****Part E - Sound*****E1 – Airborne Sound (Walls)****E2 & E3 – Airborne and Impact Sound (Floors)*****Part J – Heat Producing Appliances*****J3 – Protection of Building*****Part L – Conservation of Fuel and Energy*****Sections L1, L5, L6**

2.1 PRODUCT DESCRIPTION

This Certificate contains illustrations to explain the various elements of the Castleforms ICF Therm Wall System – these illustrations are not intended to be used as construction drawings. The Client's structural engineer in conjunction with the design team on a project, will produce a set of project specific details on a project-by-project basis. All drawings should be compliant with the relevant codes of practice and relevant standards, along with current Building Regulations.

2.1.1 Castleforms ICF Therm

Castleforms ICF Therm blocks are comprised of two EPS panels which are connected by polypropylene webs. The inner ICF panel is 75mm thick while the outer ICF panel is supplied in thicknesses of 75mm/100mm/125mm. The webs are located at 200mm centres and maintain a core thickness between the EPS panels of either 150mm or 200mm. Castleforms ICF Therm blocks are available in both straight blocks and 90° corner blocks sections. The straight ICF blocks are 400mm high and 1200mm in length. The panels are manufactured from fire retardant grade EPS in accordance with I.S. EN 13163^[1], without the use of HCFC's. The lowest density ranges between 20-24kg/m³.

The panels have castellated top and bottom edges to enable the forms to interlock together. Vertical edges are grooved to form a flush fit when joined together. To assemble, the ends of each block are butted to one another with the vertical joints staggered to form a permanent shuttering kit for walls.

Window and door openings are formed by the insertion of either Castleforms ICF Therm "vertical closer" and horizontal "header closer" panels OR "reveal closer" panels that have a built in raised reveal edge. "Vertical closer" and "header closer" panels are inserted into raised vertical castellations located on the inside faces of both the straight and corner Castleforms ICF Therm blocks while "reveal panels" are pressed home into the exposed cavity of the pre-formed opening. Alternatively, the "vertical closer" and the "header closer" could be replaced by a timber closer instead of EPS, although it would require an additional layer of EPS on the external reveal to insulate the timber.

Walls are assembled one storey at a time. Once assembled they are propped and ready-mix concrete is placed into the block cavities to create an insulated, monolithic concrete wall. The insulating formwork is clad internally and

externally and remains in place for the life of the building.

During manufacture the polypropylene web flanges are embedded within the outer surface by:

- 30mm in the 310 wall
- 55mm in the 335 wall
- 80mm in the 360 wall

The location of the web flanges is indicated on external surfaces of the panels behind the ICF Therm logo on the panel surface at 200mm vertical centres. These embedded flanges can be used as furring strips to provide a fixing for bracing during construction and allow attachment for the interior plasterboard slab wall finish. Corner rods may be installed during site installation at the internal corners of the forms to assist in the attachment of internal lining finish materials.

The top edges of the inner span of the webs have clips that give support to horizontal steel reinforcing bars where required. Each polypropylene web is designed to receive reinforcing steel in five positions across the core width. Vertical reinforcement is woven down through the horizontal reinforcement which holds it in place.

The external faces of the panels are lightly grooved vertically at 25mm and horizontally at 50mm to assist when cutting and receive the applied finishes. The formwork requires support during concrete filling.

2.1.2 Concrete

The standard concrete specification for Castleforms' ICF walls is as follows:

- Minimum Concrete Strength: C25/30 for exposure class XC1. See Table 1 for varying strength classes.
- Aggregate size: Maximum 14mm for 200mm concrete core. Where there is significant steel reinforcement within the ICF or in a 150mm concrete core a maximum 10mm coarse aggregate should be used.
- Concrete slump: S3.
- Concrete supplier certified to I.S. EN 206^[2].

Exposure Class	Strength Class	Nominal Reinforcement Cover	Min. Cement Content
XC1	C25/30	25mm	280
XC3/XC4	C25/30	45mm	300
	C28/35	40mm	320
	C30/37	35mm	340
	C40/50	30mm	360

Table 1: Concrete Strength for Exposure Class in accordance with I.S. EN 206

2.1.3 Steel Reinforcement

The steel reinforcement to be used in Castleforms ICF Therm wall should be 12-16mm diameter round or deformed bars, high tensile to BS 4449^[3], BS 4482^[4], BS 4483^[5], I.S. EN 10020^[6], IS EN 10080^[32] and I.S. EN 1992-1-1^[7], and have a maximum yield strength of 500N/mm².

2.1.4 Foundations

Castleforms ICF Therm Wall System can be used with traditional strip/pad concrete footings, raft foundations and other systems such as NSAI Agrément certified Castleforms Raft Therm. These alternative foundations are outside the scope of this Certificate. Foundation design must comply with TGD to Part A of the Building Regulations.

2.1.5 External Walls

The different elements of the external wall are as follows, from external surface to internal:

- An NSAI Agrément approved render system for EPS applied per render manufacturer's approval, instructions and conditions described in that certificate.
- 75mm/100mm/125mm EPS board (part of Castleforms ICF Therm).
- 150mm or 200mm reinforced concrete core width and polypropylene webs.
- 75mm EPS board (part of Castleforms ICF Therm).
- 12.5mm plasterboard slabs screw fixed to the embedded polypropylene web flanges.
- 4mm gypsum skin coat plaster, applied over the taped plasterboard joints or on the overall wall.

2.1.6 Compartment Walls

The compartment wall consists of the following:

- 4mm gypsum skin coat plaster, applied over the taped plasterboard joints or on the overall wall.
- 12.5mm plasterboard slabs screw fixed to the embedded polypropylene web flanges).
- 75mm EPS board (part of Castleforms ICF Therm)
- 150mm or 200mm reinforced concrete core width
- 75mm EPS board (part of Castleforms ICF Therm).

- 12.5mm plasterboard slabs screw fixed to the embedded polypropylene web flanges).
- 4mm gypsum skin coat plaster, applied over the taped plasterboard joints or on the overall wall.

Plasterboard lining may be omitted in the attic space of two storey housing, provided the space is a non-habitable area without permanent access. Hazardous items should not be stored in the attic space. A risk assessment shall be carried out if the attic space is used to house mechanical or electrical equipment.



Figure 1: Construction of Compartment Wall

Compartment walls constructed using ICF Therm Wall System meet acoustic and fire safety requirements of Building Regulations.

2.1.7 Internal Walls

Internal load-bearing walls are constructed using either a 150mm or 200mm Castleforms ICF Therm concrete core wall, slabbed and plastered as per Section 2.1.6.

Alternatively, traditional masonry block internal walls, timber or metal stud internal walls can also be used with the system. It is important to ensure these walls are securely tied to the external ICF concrete core.

2.1.8 Ground Floors

Generally, ground floors can be constructed as ground bearing or suspended substructures. Ground floor structure is outside the scope of this certificate. Ground floor design must comply with TGD to Part A and Part C of the Building Regulations. Possible ground floor solutions are listed below.

Ground Floor with ICF Rising Walls

Where a ground bearing slab is specified, the floor insulation, concrete slab and/or floor screed is placed directly up to the inside of the Castleforms ICF Therm rising wall.

Suspended Ground Floor Slabs

Where site or ground conditions require the use of a suspended ground floor slab, this is achieved using pre-cast concrete slab or other forms of suspended floor construction. The slab is seated on a bed of mortar bearing directly onto the ICF concrete core. The bearing surface should be nominally 100mm, minimum 75mm, as specified in I.S. EN 1992-1-1^[7]. Refer to pre-cast floor manufacturer instructions regarding minimum slab end bearing.

Raft slab including Castleforms Raft Therm

Where a raft slab is specified, it shall be constructed in accordance with Client's structural engineer specification. Shims and starter tracks shall be used for placing ICF Therm wall on raft foundation. Proprietary NSAI Agrément certified raft solutions such as Castleforms Raft Therm may be used with Castleforms ICF Therm Wall System as per manufacturer's specification.

2.1.9 Intermediate and Compartment Floors

Castleforms ICF Therm system enables the use of different flooring systems including solid or open web timber joists, concrete pre-cast beams and hollowcore slabs. Compartment floors shall have appropriate fire resistance. Floor structure is outside the scope of this certificate. Floors design must comply with TGD to Part A of the Building Regulations. Possible floor solutions are listed below.

Precast Concrete Floor

Where precast concrete beams or slabs are specified for upper floors, the beam ends are laid on a bed of mortar and directly onto the ICF concrete core. The bearing surface should be nominally 100mm, minimum 75mm, as specified in I.S. EN 1992-1-1^[7]. Refer to precast floor manufacturer instructions regarding minimum beam/slab end bearing.

Reinforcing steel from the lower wall is centred in the remaining gap between the precast beam/slab end and the outer ICF form and extended into the ICF block courses for the following storey. To complete the floor to wall connection, a 90° reinforcing steel is fixed into the load bearing wall and is tied into the floor screed.

The minimum cover to the vertical reinforcing steel must be at least 25mm, as specified. A concrete floor screed, typically 75mm, is placed over the pre-cast beams. The floor reinforcing steel design is specified by a Client's structural engineer.

Timber Joist Floor

First floors can be formed using solid or open web timber floor joists fixed into the load bearing walls using the Simpson Strong Tie Ledger System or similar, where the inner leaf of EPS is removed at

that location and the system is fixed directly to the concrete core. Alternatively, prior to concrete placement holes are formed at intervals along ICF block course at first floor level, these holes are then temporarily sealed with plywood strips and the wall filled with concrete. Later the plywood strips are removed exposing a flush concrete face to which a ledger board is securely fixed.

2.1.10 Roof

While roofs are outside the scope of this Certificate, the Castleforms ICF Therm Wall System allows for the supply by others of a conventional timber or trussed roof with slating or tiling in accordance with SR 82^[8].

2.1.11 Stairs

Stairs are not part of the Castleforms ICF Therm Wall System and are not covered by this Certificate.

2.1.12 Chimney

Chimneys are not part of the Castleforms ICF Therm System and are not covered by this Certificate. The requirements of Clause 2.15 of TGD to Part J of the Building Regulations require that combustible material such as polystyrene insulation have at least the following separation distance:

- a) 200mm from a flue, or
- b) 40mm from the outer surface of a brick or blockwork chimney or fireplace recess.

2.1.13 External Finish

The external faces of the Castleform ICF Therm panels are lightly grooved vertically and horizontally to receive the applied finishes. A light rasping is required to ensure good adhesion.

NSAI approved EPS external render, with a minimum B-s1, d0 fire classification, can be applied directly to the EPS in the Castleforms ICF Therm walls as per render manufacturer's approval, instructions and conditions described in that certificate. Render to meet requirements of Section 3 & 4 of this certificate, including EPS characteristics as per Table 2.

Alternative finishes compatible with Castleforms ICF Therm walls include traditional brick/stone outer leaf cladding.

Before any external finish is applied all fire barriers must be fitted opposite all compartment walls and compartment floors (see Section 3.2).

2.1.14 Ancillary Items

- Anchor bolts;
- Simpson Strong Tie Ledger connection or similar;
- PVC pipe sleeves for penetrations;
- Course thread drywall screws 4.2mm+65mm
- Corner fixing strips – polypropylene fixing strips (90 deg. angle);

- ICF push/pull braces
- Radon membrane/barrier;
- Low-Expanding foam adhesive;
- Hot knives and Grooving tools;
- Bracing and alignment system;
- Brickwork/stonework ties;
- Waterproofing membrane;
- Fire stops.

These items are outside the scope of this Certificate.

2.2 MANUFACTURE

All Castleforms' EPS components are manufactured in accordance with I.S. EN 13163^[1]. The modular units are moulded with the interlocks and with markings on the block face showing the locations of the polypropylene connectors. Each EPS building block is manufactured with its integral polypropylene connectors. Production is controlled at different stages through inspections and quality control checks per the Castleforms Quality Manual and Inspection Schedule.

See Table 2 for the EPS characteristics used in the Castleforms ICF Therm Wall System.

2.3 DELIVERY, STORAGE AND MARKING

The Castleforms ICF Therm products are delivered to site poly-wrapped. The wrapping should not be opened until the contents are required. All packaged components are clearly labelled with product type and production date allowing full traceability of supply.

Castleforms ICF Therm Wall System components should not deteriorate in normal storage conditions so long as they remain in their packaging protected from the environment prior to use. Storage must be on firm, level and dry ground, and if the components are to be stored outside, they may be further protected from the weather by a secured covering. Castleforms ICF Therm Wall System materials should be protected from prolonged exposure to direct sunlight and must not be exposed to plastic materials containing plasticizers or to volatile aggressive solvents. The polystyrene must not come into contact with aggressive chemicals or deleterious agents, e.g., diesel oil, petrol, various cleaning solvents, hydrocarbons, membranes containing coal tar pitches or building products containing solvents. Reasonable care must be taken to prevent damage to forms before, during and after installation. The formwork panels must not be punctured, split, deformed, or unduly compressed before use.

2.4 INSTALLATION

2.4.1 General

This Certificate does not contain a complete set of installation instructions, but an overview of the procedures involved. For a full list of these instructions, refer to the Certificate holder's manuals. Should a conflict arise between this

Certificate and the Certificate holder's manuals, this Certificate shall take precedence.

Site construction is undertaken using trained installers in accordance with the Castleforms' Installation Manual. Trained installers must:

- Work in compliance with the Castleforms ICF Therm Wall System installation manuals.
- Be familiar with the requirements of this Agrément certificate.
- May be subject to supervision by Castleforms, including unannounced site inspections

If a render finish is to be applied to the ICF Therm walls, a pre-rendering checklist report shall be completed before rendering commences, which shall include checking that all fire barriers are correctly installed. The external render system shall be applied by trained installers of render onto EPS systems. Installers of render shall be trained by render NSAI Agrément Certificate holder and render applied in accordance with the render specification. Refer also to section 2.4.12 for post pour checklist.

Concrete working best practice should be followed in both hot and cold conditions. The concrete may be placed when the air temperature is between 5°C and 30°C.

2.4.2 Foundations

Foundations are not covered by this Certificate. However, foundations and substructures must comply with the relevant clauses of BS 8004^[9], I.S. EN 1992-3^[10] and BS 8102^[11], as appropriate, and must provide a flat and level footing for the installation. Any reinforcing bars cast into the substructure must be positioned such that they allow for compaction and located in the system with adequate concrete cover for protection. The foundation base from which the Castleforms ICF Therm Wall System is to be built must be checked to ensure it is clean, flat and level.

2.4.3 Damp Proof Course (DPC)

While Castleforms ICF Therm formwork does offer a degree of resistance to moisture ingress, an effective DPC is still required at the ground floor/external wall junction. This can be achieved by one of the following methods.

Plastic DPC

A plastic DPC is fitted underneath the first course of Castleforms ICF Therm block at ground floor level. For ease of application, the inter-locking lugs can be removed. DPC shall be certified to EN 13967.

Waterproof Concrete

Forms with appropriate materials and workmanship can produce adequately damp-proof structures by using a layer of water resisting concrete, a minimum of 150mm above external

ground level, in accordance with Type B structures defined in BS 8102^[11].

2.4.4 Wall Assembly

For each wall a chalk line is used to mark the inside edge of the first course of ICF Therm blocks onto the foundation. Starter tracks shot fired to the foundation help to ensure the first course of ICF Therm blocks are aligned during initial set out, subsequent courses thereafter are also kept true and straight.

For full wall assembly instructions refer to Castleforms' Installation Manual including openings forming, cutting, vertical joints placement and sealing.



Figure 2: Castleforms ICF Therm Wall and Starter Track

All cuts and weak spots must be reinforced or glued. L rods shall be inserted into internal corners to facilitate the fixing of plasterboard here. Internal wall formwork is jointed into external formwork by removal of a vertical slice.

Where the specified elevation height is not a multiple of the standard form, units may be trimmed using woodworking tools.

The formation of door and window openings using vertical closer and header panels must be carefully carried out.

2.4.5 Reinforcement Placement

For Castleforms ICF Therm walls horizontal rebar can be secured in five optional slots across the concrete fill void using the top of each plastic web.

Horizontal reinforcing bars for lintels must be located within the lintel as specified in the structural design, the minimum length of bar will

be specified by the Client's structural engineer to ensure that adequate anchorage has been allowed for either side of an opening.

Vertical reinforcement can then be secured to horizontal reinforcement at required centres using standard fixing methods. Bar lapping lengths as per I.S. EN 1992-1-1^[7] should be adopted.

The system requires that in plain walls horizontal reinforcement be provided in top and bottom courses of every wall lift. The reinforcement is checked to ensure there is adequate concrete cover for protection and that compaction can take place. The horizontal and vertical reinforcement shall be specified by the Client's structural engineer (see Clause 3.1.1 of this certificate).

2.4.6 Bracing

To achieve structurally stable formwork during the construction process, the system must be temporarily braced sufficiently to provide lateral support during the pouring of the concrete and post-pouring stage. The installer is responsible for ensuring the adequacy of all temporary bracing.

It is essential that effective bracing and propping of walls takes place during construction to ensure stability, level, straightness and plumb of walls. At a minimum, the full height of the assembled formwork system must be supported 400mm from corners and along the length of each wall at maximum vertical centres of 1.5m for 150mm core walls and 1m for 200mm core walls.

Generally, the bracing and propping systems are placed on one side of the formwork, usually the inside face, and at every corner during construction. However, for very long walls or walls greater than one storey in height, bracing on two sides is recommended. On exposed sites or in adverse weather conditions additional temporary support should be provided.

All lintels must be adequately supported until the concrete has attained its minimum working strength. Whenever an opening is within 2400 mm from a corner, strapping or corner bracing must be provided to prevent movement between the corner and the opening. As pouring proceeds, the alignment and plumb of the wall forms should be checked and re-levelled by adjusting the propping systems diagonal brace.

Bracing systems used in conjunction with the EPS system must be checked prior to and during the concrete pour to ensure stability and alignment is maintained.



Figure 3: Bracing System for Castleforms ICF Therm Walls

2.4.7 Openings

The rigidity of the formwork is reduced by window and door openings but is increased by the incidence of corner and crosswall details. Openings are formed during construction of the formwork.

Castleforms ICF Therm “vertical closer” and horizontal “header closer” and “reveal closer” EPS panels are used to form window and door openings. Window and door frames are fitted directly up to the closer panels creating an effective perimeter insulation barrier around each opening to prevent cold bridging. Alternatively, the “vertical closer” and the “header closer” could be replaced by a timber closer instead of EPS, although it would require an additional layer of EPS on the external reveal to insulate the timber.

“Vertical closers” and “header closers” are inserted into raised vertical castellations located on the inside faces of both the straight and corner Castleforms ICF Therm blocks. Both panels are flippable and reversible.

The “vertical closer” is designed to move in 10mm increments to allow optimum accuracy in the location of openings. Interlocking lugs are located on the top and bottom of each closer.

The “header closer” is supplied in 1200mm lengths and are butted end to end for larger openings.

If the “vertical closer” and the “header closer” are replaced by a timber cavity closer the positioning is flexible due to the absence of interlocking lugs in the timber. This allows an exact positioning.

The “reveal closer” panels are pressed home into the exposed cavity of the pre-formed openings and are supplied in 2m lengths.

Window and door frames are externally sealed using reveal beads with a built-in gasket seal. A flexible mastic sealant may also be used to seal

joints around openings. Suitable lintel design will be specified by the Client’s structural engineer.

2.4.8 Services

Wall openings or ducts for service penetrations can be positioned within the formwork prior to concrete pouring. At all service entry points, care must be taken to effect a properly sealed joint to prevent the ingress of vermin or moisture. Gaps in the insulation may be made good by filling and sealing with a self-expanding polyurethane foam. Service entry points to basement walls should be avoided.

Where services are to penetrate the wall, a duct or sleeve through the Castleforms ICF Therm Wall System should be inserted prior to placing the concrete.

Electrical cables shall be prevented from coming into contact with expanded polystyrene by enclosure in conduits or trunking in accordance with I.S. 10101^[15]. Electrical sockets and switches shall be installed in PVC or metal boxing.

Service penetrations in compartment walls shall be fire stopped by specialists in the field.

2.4.9 Pre-Pour Checks

Once the bracing and propping is erected, adjustments are made for plumb, alignment and level by use of the push/pull screws. Reinforcement should be checked for correct cover distance and rigidity. Before the initial pour and between concrete pours, care must be taken to remove any debris from inside the formwork. All reinforcement must be checked by a competent registered installer and/or Client’s engineer.

2.4.10 Concrete Placement

Adequate supervision and care by the installer is needed when placing concrete. Concrete can be placed using line pump or overhead boom from a concrete pump lorry moving around the structure in a circular fashion.

The concrete should be directed into the central cavity away from corners and not directly against the polystyrene units in 1.2m lift height allowing concrete to free flow into corners and below window openings. The first lift is allowed to stiffen before placing the second lift of concrete. Typically, storey heights should be placed in two storey lifts. When forming construction joints between concrete pours, these should be located within 100mm of the top of the Castleforms ICF Therm Wall System for ease of access and visual checking. Construction joints should be horizontal rather than vertical.

Lintels must be filled with concrete in a single operation, ensuring that the concrete integrates fully with the concrete in the walls at both ends.

To avoid the creation of voids, particular attention should be paid at locations where the flow of concrete may be impeded such as around corners, at service pipe locations or an opening/lintel where additional steel rebar is fixed, as the steel can impede the flow of concrete around these sections. To prevent damage to the system, the use of poker vibrators above 25mm diameter is not recommended, however care must be taken not to exert excessive pressure on the system by overuse of vibrators and should be kept back from the corner approximately 1m.

Small volumes of concrete can be placed by hand, e.g., to make up small deficiencies at the end of each pour or to the sill of window openings.

During concrete placement, the surface of the formwork is tapped at critical areas with a flat wooden mallet to check for a distinctive hollow sound indicating a possible void which is corrected. If necessary, at a later stage EPS can be removed to inspect consolidation of concrete and remedial action taken, the EPS is easily bonded back in using a low expanding foam.

In very hot or freezing conditions, the top of the Castleforms ICF Therm Wall System must be covered to protect the concrete from adverse curing conditions.

The recommended concrete pour rate is 1000 to 1200mm/hr with a maximum of 1500mm/hr in warm temperatures. The formwork system is filled and compacted progressively in layers not exceeding 1.2m lifts with a total daily concrete pour height not exceeding 3m (i.e., one storey height). This is to ensure adequate compaction is achievable and to avoid possible displacement of any reinforcement and excessive pressure being exerted on the Castleforms ICF Therm System.

2.4.11 Concrete Compaction

Adequate consolidation/compaction of the concrete in line with I.S. EN 1992-1-1^[7] is essential and the concrete must be placed so that it completely fills Castleforms ICF Therm Wall System without creating any voids.

Particular attention should be given to basement walls and areas around openings. Concrete in lintels must be mechanically tamped or vibrated to ensure proper compaction around any steel reinforcement.

Where reinforcement is present for structural purposes, mechanical vibration is essential with internal poker vibrators smaller than 25mm diameter. Special care is required to avoid touching the formwork when using this equipment. Where internal poker vibrators are used, these should be confined to the central concrete core between reinforcement layers and

used in accordance with the Certificate holder's instructions.

The completeness of filling of the formwork can be easily confirmed by tapping its surface (with the palm of the hand or a wooden mallet) – any voids will be detected by a distinctive hollow sound. This should be done as the concrete is placed so that any voids detected can be easily corrected. The compaction of the concrete can be confirmed by tapping the surface as described up to 2.8m high walls. For load bearing walls above this height, the EPS can be removed to inspect the concrete core or alternatively, normal concrete cores can be taken as required.

2.4.12 Post-Pour Tasks

After pouring is complete, immediately check the walls are straight and vertical adjusting the bracing support as required.

Any damage to the forms should be repaired immediately and any concrete spillage or leakage of grout may be removed by hosing down the exposed face of the system before it sets.

The concrete in the Castleforms ICF Therm Wall System must be left to cure until it has achieved a specified minimum strength, usually after two or three days, for construction to continue. Structural fixings should not be loaded until the concrete has achieved a sufficient strength and supports should be left in place as long as required.

Where lateral bracing walls and other structures are intended to act in concert with the concrete filled forms, the polystyrene face must be removed to allow the required structural connection between the concrete core and the supplementary structure.

Backfilling around bottom layers of formwork to the ground floor walls should not take place until the concrete has reached sufficient design strength, i.e., a minimum period of seven days.

Any damage to the faces of the Castleforms ICF Therm System must be made good prior to the application of the internal and external finishes.

ICF Therm Wall System surface shall be inspected prior to render application to ensure the surface is adequate for rendering. Where the panels are damaged for example mechanically or by weather conditions, the manufacturer shall be contacted to confirm if the surface of EPS is adequate for applying finishes.

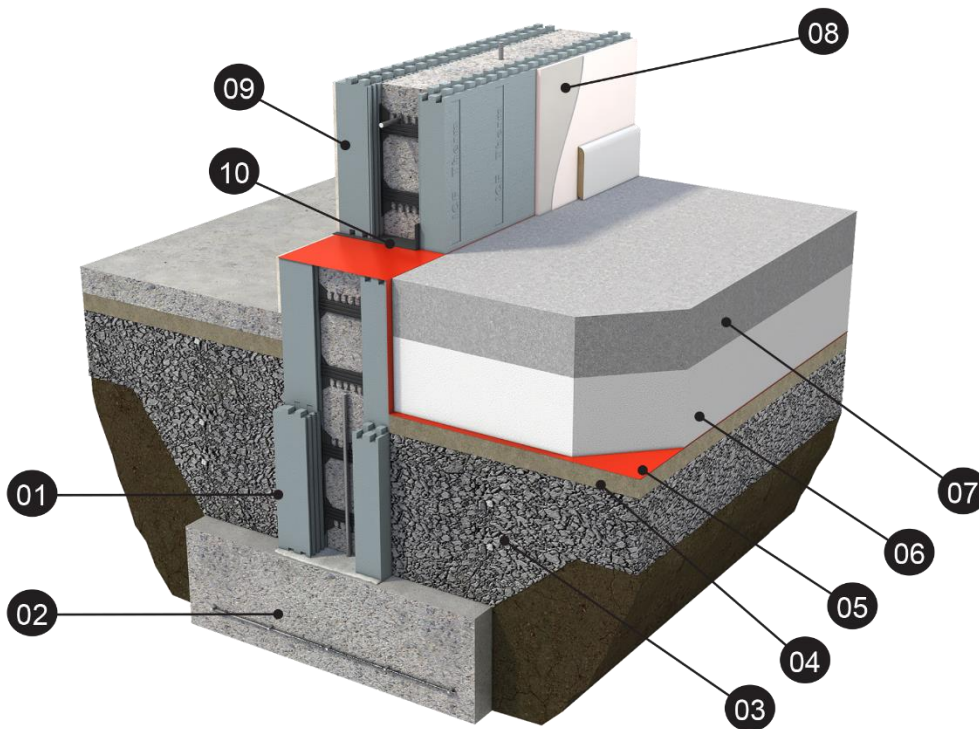

- | | |
|--|---|
| <p>01. First course set and levelled on shims or starter track. Fill gaps with low-expanding PU-Foam.</p> | <p>07. Concrete slab as specified.</p> |
| <p>02. Strip foundations to engineers specification and detail as per TGD Part A.</p> | <p>08. 12.5mm Gypsum plasterboard, screw fixed to ICF.</p> |
| <p>03. Compacted graded stone fillin accordance with S.R.21:2014 + A1:2016 & Annex E.</p> | <p>09. Approved EPS render.</p> |
| <p>04. Sand Blinding layer.</p> | <p>10. DPC</p> |
| <p>05. Radon barrier / DPM lapped and taped where appropriate.</p> | |
| <p>06. EPS or other approved insulation.</p> | |

Figure 4: Castleforms ICF Therm Wall With a Strip Foundation And a Ground Bearing Slab

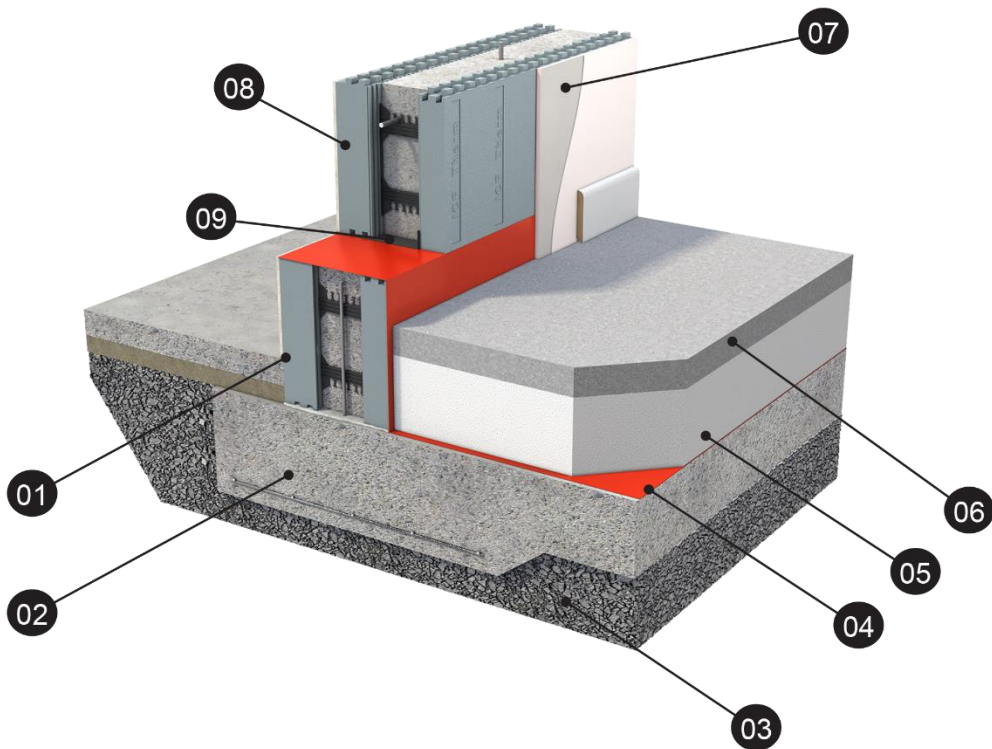

01. First course set and levelled on shims or starter track. Fill gaps with low-expanding PU-Foam.

02. Concrete raft foundations to engineers specification and detail.

03. Compacted graded stone fill in accordance with S.R.21:2014 + A1:2016 & Annex E.

04. Radon barrier / DPM lapped and taped where appropriate.

05. EPS or other approved insulation.

06. Finished floor screed.

07. 12.5mm Gypsum plasterboard, screw fixed to ICF.

08. Approved EPS render.

09. DPC

Figure 5: Castleforms ICF Therm Wall And a Concrete Raft Foundation Detail

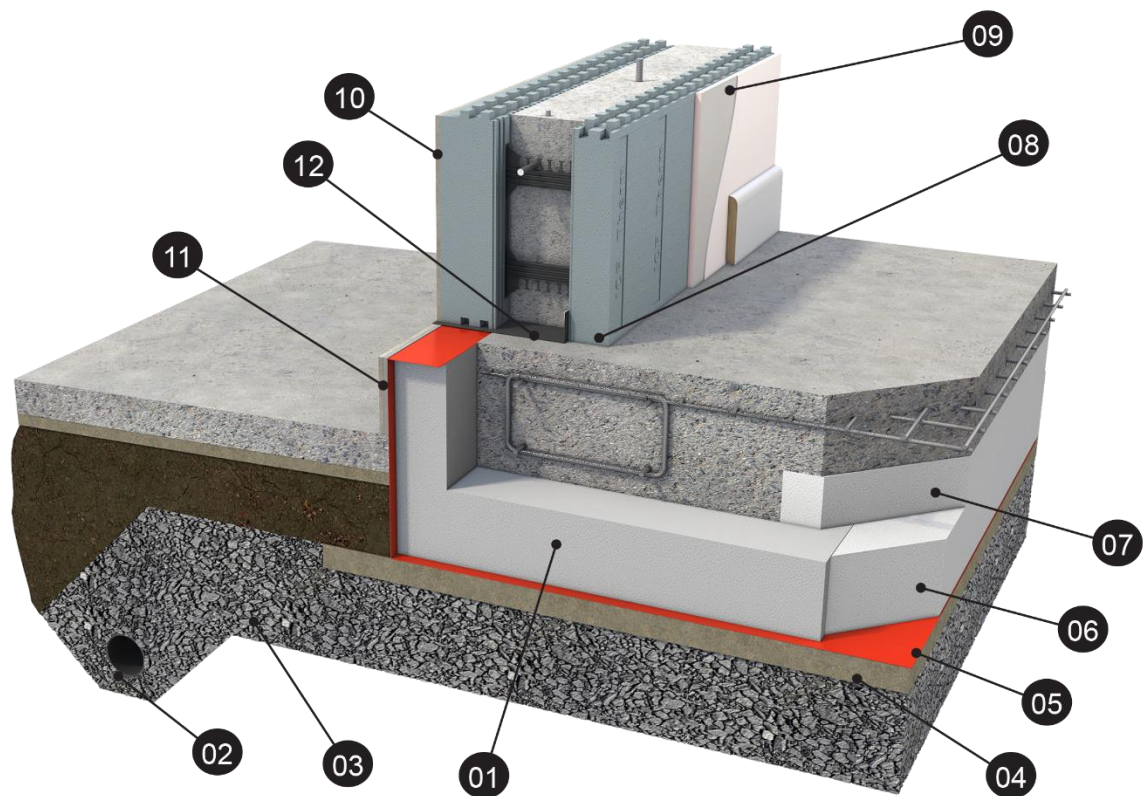

01. Insulated Raft Foundation Foundation to engineers specification and detail. L-Section (Dimension varies).

02. Land-drain around perimeter of building.

03. Compacted graded stone fill in accordance with S.R.21:2014 + A1:2016 & Annex E. Typically T3 blinding on T2 permeable on T1 structural.

04. Sand Blinding layer.

05. Radon barrier / DPM lapped and taped where appropriate.

06. EPS Floor Insulation.

07. EPS Floor Insulation.

08. First course set and levelled on shims or starter track. Fill gaps with low-expanding PU-Foam.

09. 12.5mm Gypsum plasterboard, screw fixed to ICF.

10. Approved EPS render.

11. Cement board & render.

12. DPC

Figure 6: ICF Wall & Raft Therm Foundation with Radon/DPM below EPS dressed Up To The Outside Of The Perimeter L Section

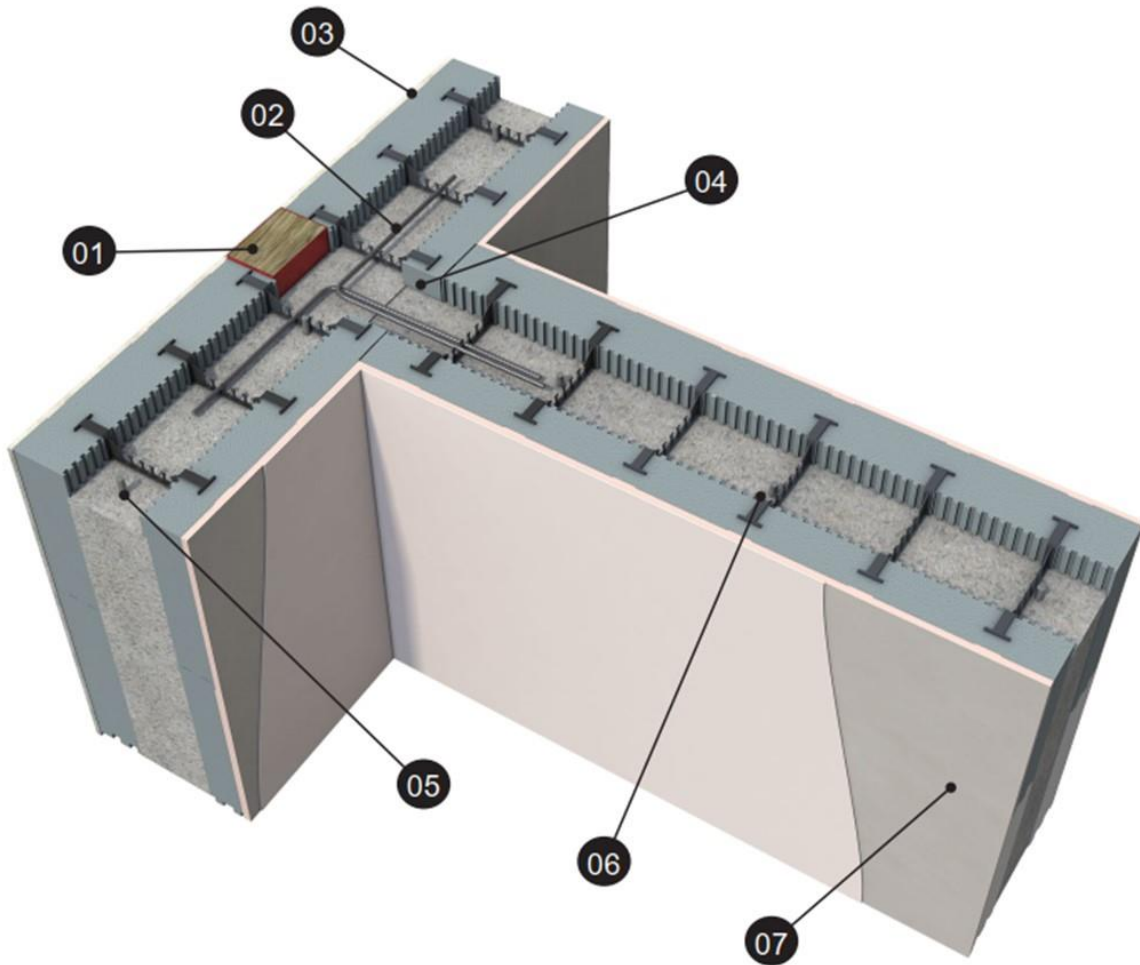

01. At compartment wall, 100mm-200mm vertical fire stop (e.g. mineral wool) mechanically fixed at 300mm centres with stainless steel fixings.

02. 90 degree wall to wall steel reinforcing, alternate overlap on each side of T-Wall.

03. IAB approved EPS render.

04. Remove portion of internal panel to accomodate T-Wall.

05. Vertical steel reinforcement to engineers specification.

06. Wall steel reinforcement inserted between floors as per engineers specification.

07. 12.5mm Gypsum plasterboard, screw fixed to ICF.

Figure 7: Typical Compartment Wall to External Wall Junction Detail with a Mineral Wool Fire Stop

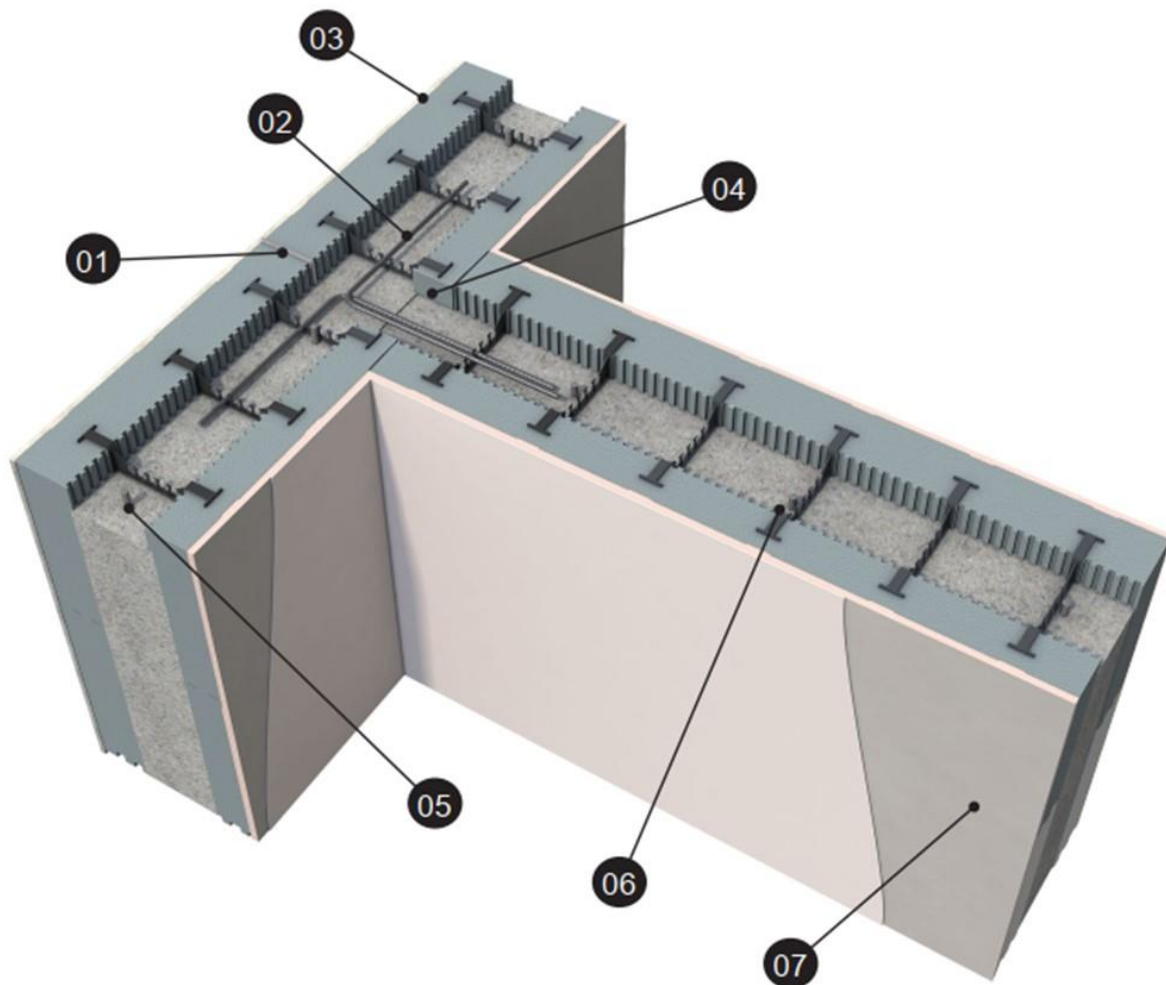

01. At compartment wall, Galvanized vertical fire stop inserted into forms.

02. 90 degree wall to wall steel reinforcing, alternate overlap on each side of T-Wall.

03. IAB approved EPS render.

04. Remove portion of internal panel to accomodate T-Wall.

05. Vertical steel reinforcement to engineers specification.

06. Wall steel reinforcement inserted between floors as per engineers specification.

07. 12.5mm Gypsum plasterboard, screw fixed to ICF.

Figure 8: Typical Compartment Wall to External Wall Junction Detail with Metal Strip Fire Stop

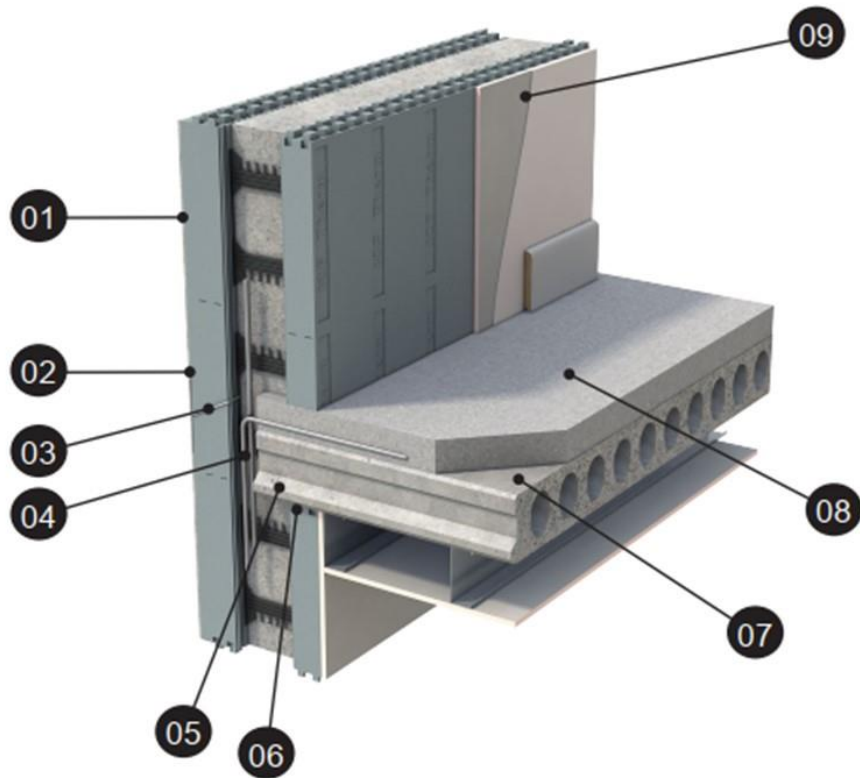

01. IAB approved EPS render

02. Additional mesh reinforcement applied over fire break location.

03. Fire Break. Galvanized metal strip, cut into ICF panels at appropriate floor levels. Fire Strip to angle downwards.

04. 90 degree floor to wall steel reinforcing.

05. Minimum 75mm end bearing onto concrete core.

06. 10mm mortar bed.

07. Precast floor to engineers specification.

08. 75mm floor screed with reinforcement mesh.

09. 12.5 gypsum plasterboard screw fixed to ICF.

Figure 9: Castleforms ICF Therm Wall with a Compartment Precast Floor Detail

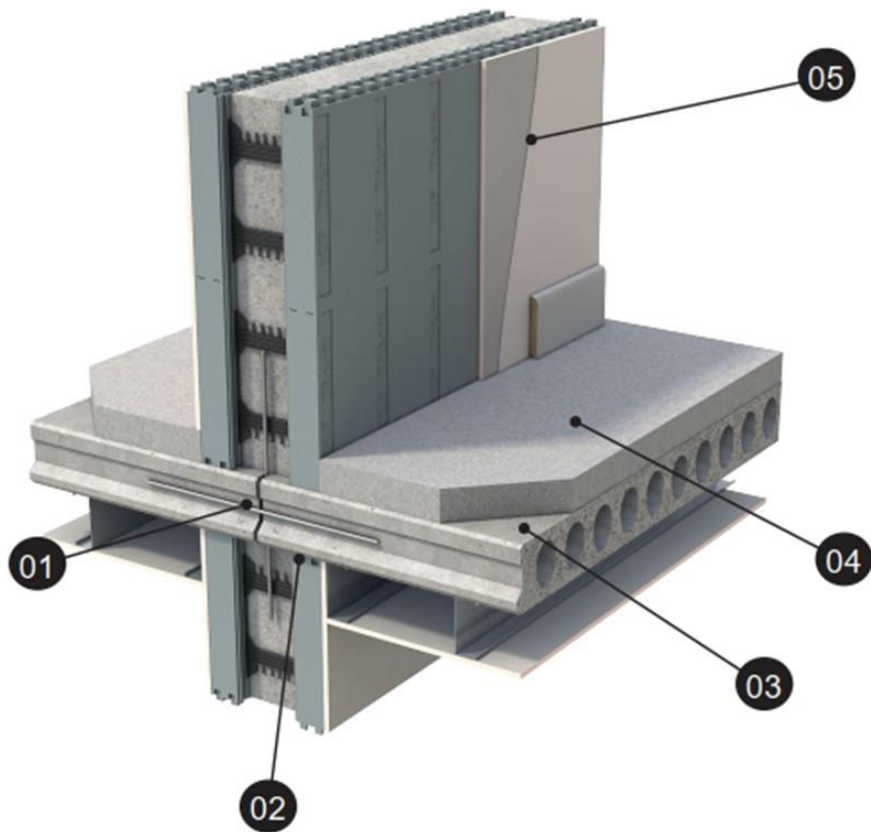

- 01. Horizontal steel reinforcing. Grout across joint as per engineers specification.
- 02. 10mm mortar bed.
- 03. Pre cast concrete floor to engineers specification.
- 04. 75mm floor screed with reinforcing mesh.
- 05. 12.5mm gypsum plasterboard screw fixed to ICF.

Figure 10: Compartment Precast Hollowcore Floor on the ICF Therm Interior Compartment Wall

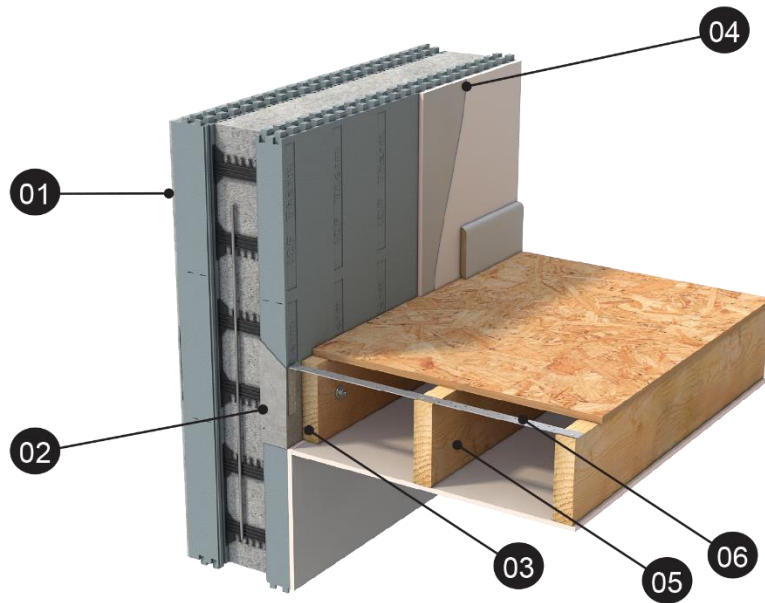

- 01. IAB approved EPS render
- 02. Cut out portion of the inner ICF panel prior to concrete placement.
- 03. Timber Ledger fixed to exposed concrete.
Anchor Bolts @600mm Centers.
- 04. 12.5 Gypsum Plasterboard screw fixed to ICF.
- 05. Joists parallel to wall.
- 06. Galvanised strap screw fixed to joists and screw fixed to concrete pocket.

Figure 11: Intermediate Timber Floor Detail – Floor Joists Parallel to External ICF Therm Wall.

Note: Fire stopping may be required if cavities are present. Refer to section 3.2.1

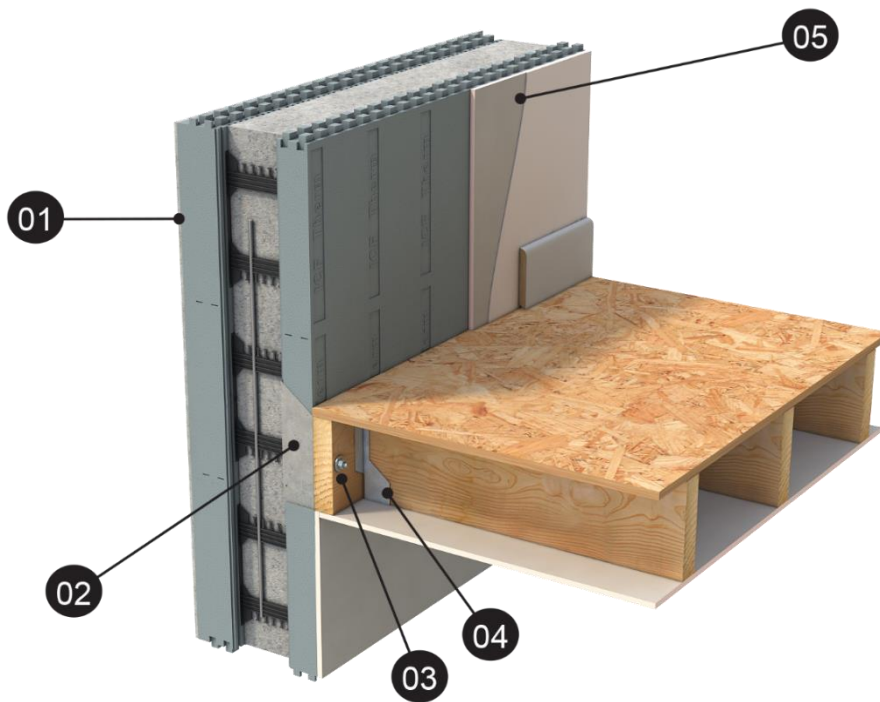

01. IAB approved EPS render

02. Cut out portion of the inner ICF panel prior to concrete placement.

03. Timber ledger fixed to exposed concrete.
Anchor bolts @600mm centers.

04. Joist Hangers.

05. 12.5 gypsum plasterboard screw fixed to ICF.

Figure 12: Intermediate Timber Floor Detail – Timber Floor Joists Perpendicular to the External ICF Therm Wall

Note: Fire stopping may be required if cavities are present. Refer to section 3.2.1

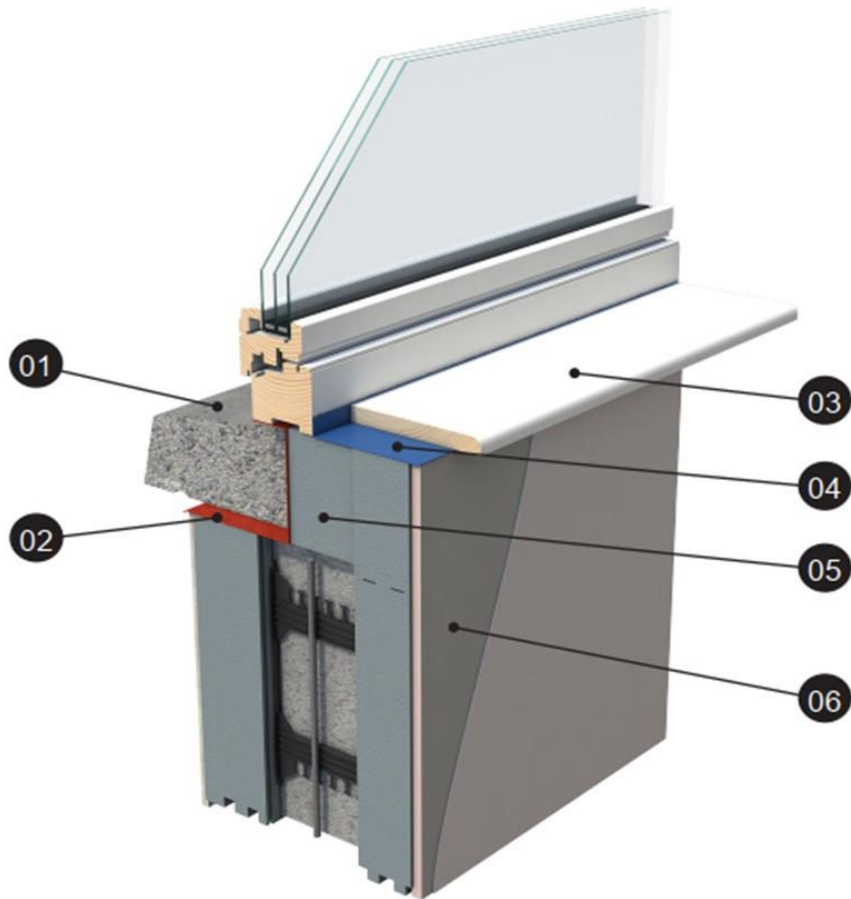

01. Concrete Cill. Cill projects a min. of 50mm
Ensure water drip is a min. of 15mm from
finished wall.

02. DPC dressed under and up behind window
cill.

03. Window Board.

04. Approved airtightness tape.

05. Insulation to back of cill.

06. 12.5mm Gypsum plasterboard,
screw fixed to ICF.

Figure 13: Typical Window Cill Detail

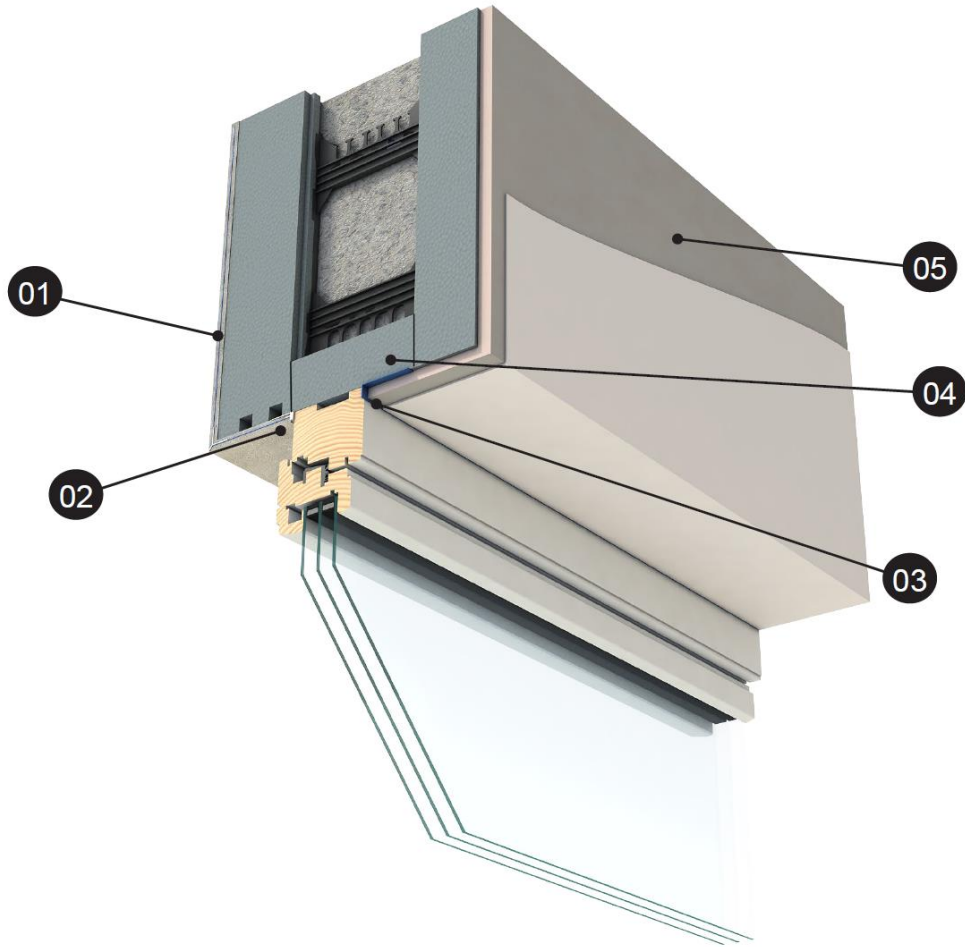

01. IAB approved EPS render.

02. Seal window frame using Sotherm Reveal Bead with gasket seal or similar and silicone seal.

03. Approved airtightness tape.

04. Header Block.

05. 12.5mm Gypsum plasterboard, screw fixed to ICF.

Figure 14: Typical Window Head Detail With Header Block

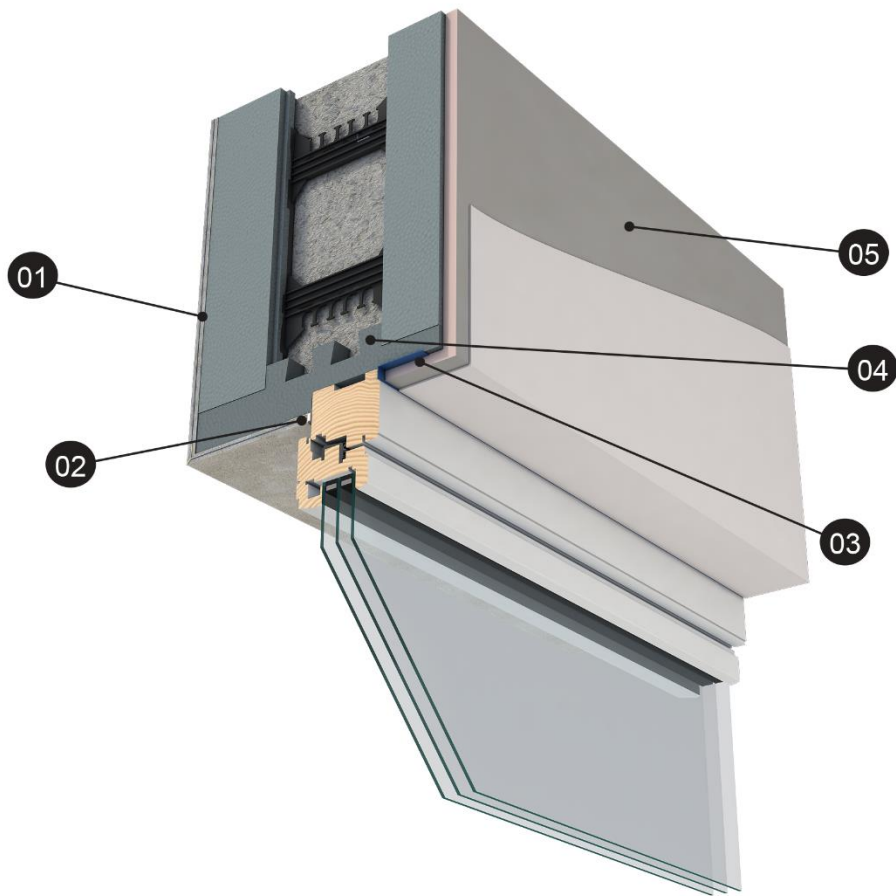

01. IAB approved EPS render.

02. Seal Window frame using Sotherm Reveal Bead with gasket seal or similar and silicone seal.

03. Approved airtightness tape.

04. Header Closer with raised reveal.

05. 12.5mm Gypsum plasterboard, screw fixed to ICF.

Figure 15: Typical Window Head Detail With EPS Header Closer with Raised Reveal

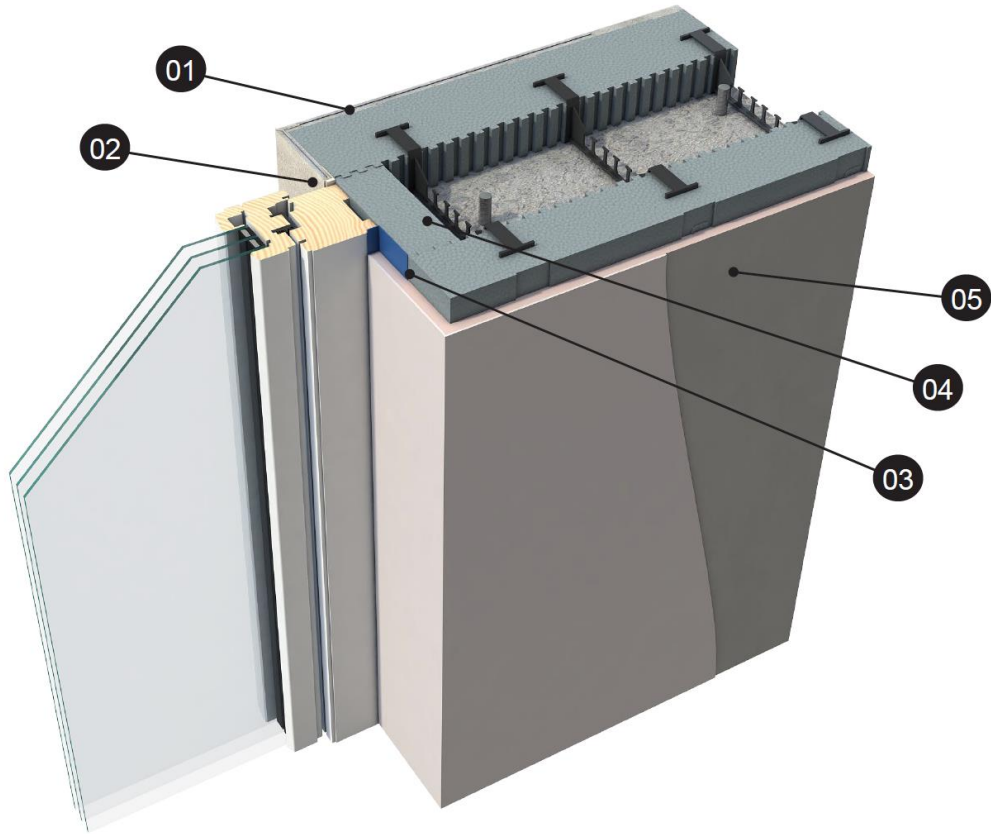

- 01. IAB approved EPS render.
- 02. Seal window frame using Sotherm Reveal Bead with gasket seal or similar and silicone seal.
- 03. Approved airtightness tape.
- 04. EPS Vertical Closer.
- 05. 12.5mm Gypsum plasterboard, screw fixed to ICF.

Figure 16: Typical Window Reveal Detail With EPS Vertical Closer

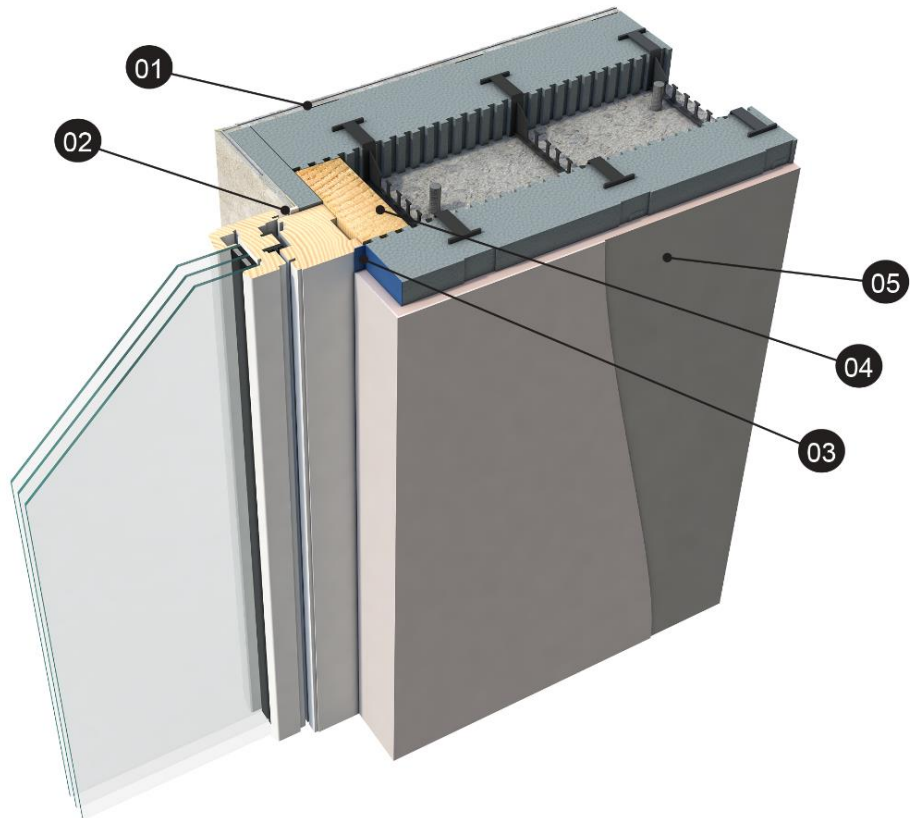

- 01. IAB approved EPS render.
- 02. Seal window frame using Sotherm Reveal Bead with gasket seal or similar and silicone seal.
- 03. Approved airtightness tape.
- 04. Timber Vertical Closer.
- 05. 12.5mm Gypsum plasterboard, screw fixed to ICF.

Figure 17: Typical Window Reveal Detail With Timber Vertical Closer

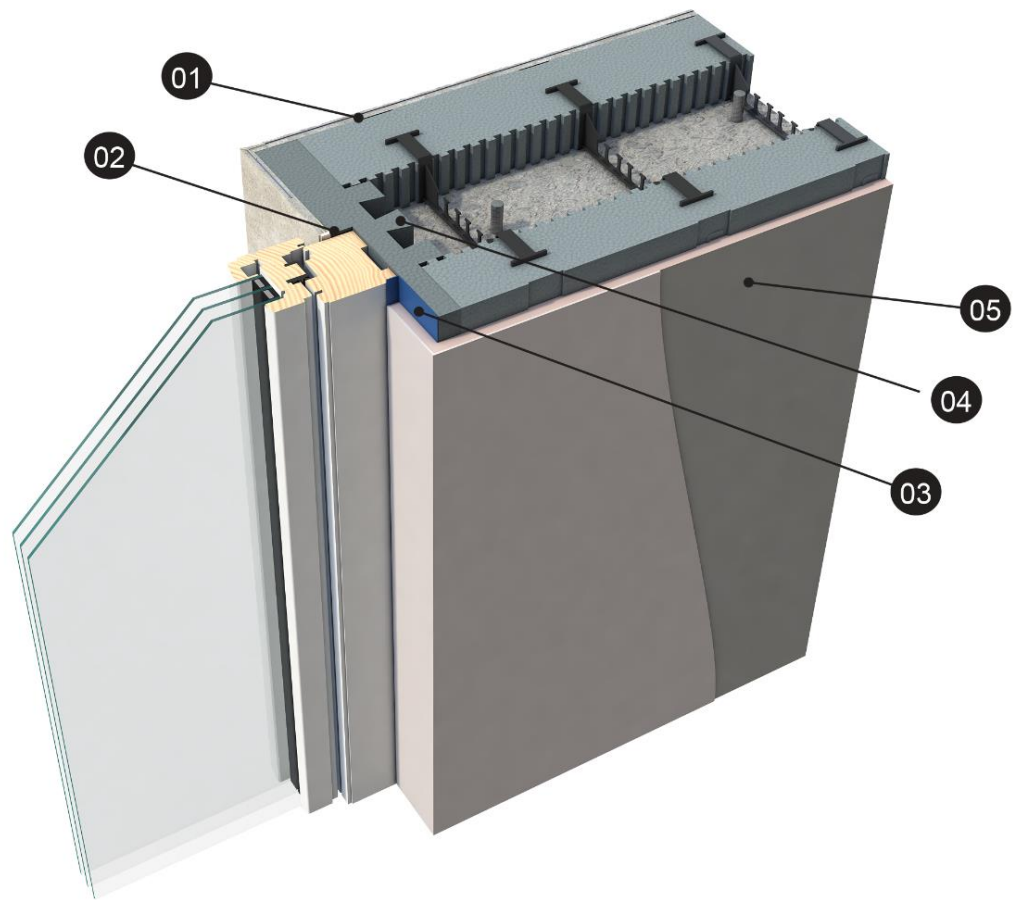

01. IAB approved EPS render.

02. Seal Window frame using Sotherm Reveal Bead with gasket seal or similar and silicone seal.

03. Approved airtightness tape.

04. EPS Vertical Closer with raised reveal.

05. 12.5mm Gypsum plasterboard, screw fixed to ICF.

Figure 18: Typical Window Reveal Detail With EPS Vertical Closer with Raised Reveal

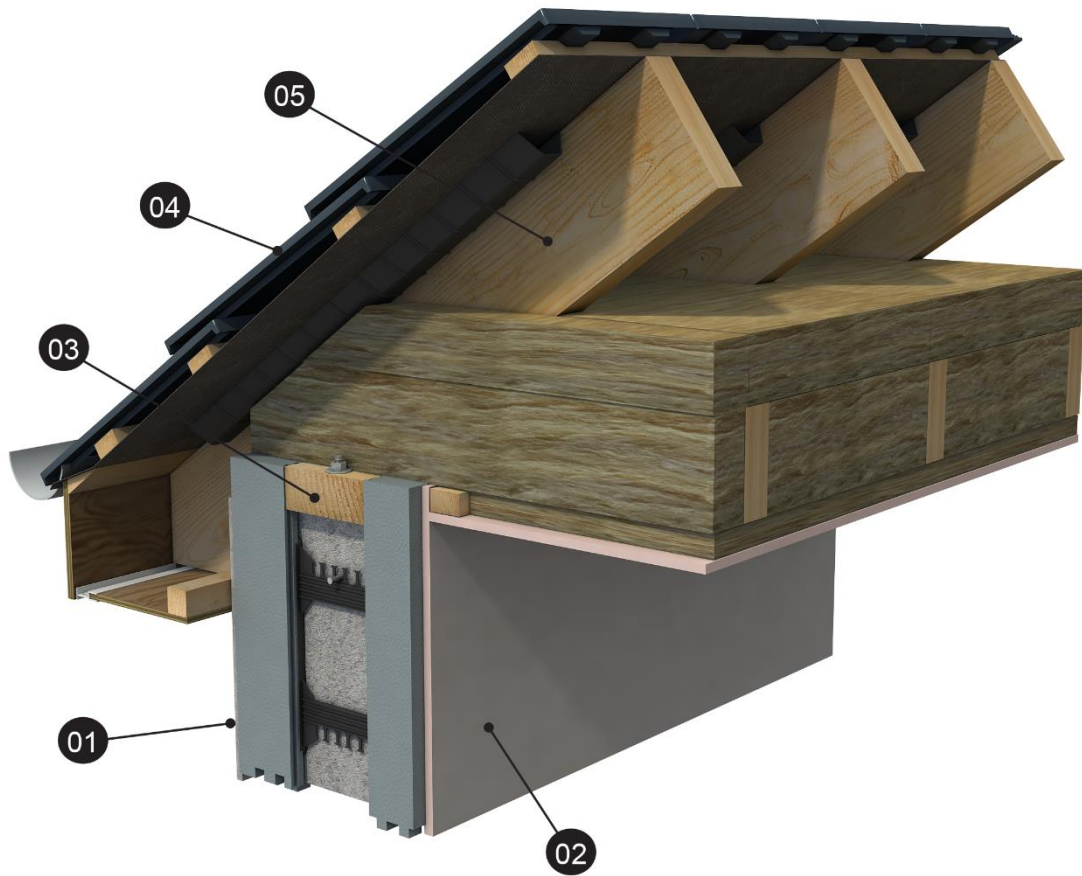

01. IAB approved EPS render.

02. 12.5mm Gypsum plasterboard,
screw fixed to ICF.

03. 150mm x 44mm wall-plate.
Anchor bolts to engineers specification.

04. Roof Finish

05. Rafter.

Figure 19: Typical Eaves Detail Where Firestopping is Not Required

Note: Fire stopping may be required if cavities are present. Refer to section 3.2.1

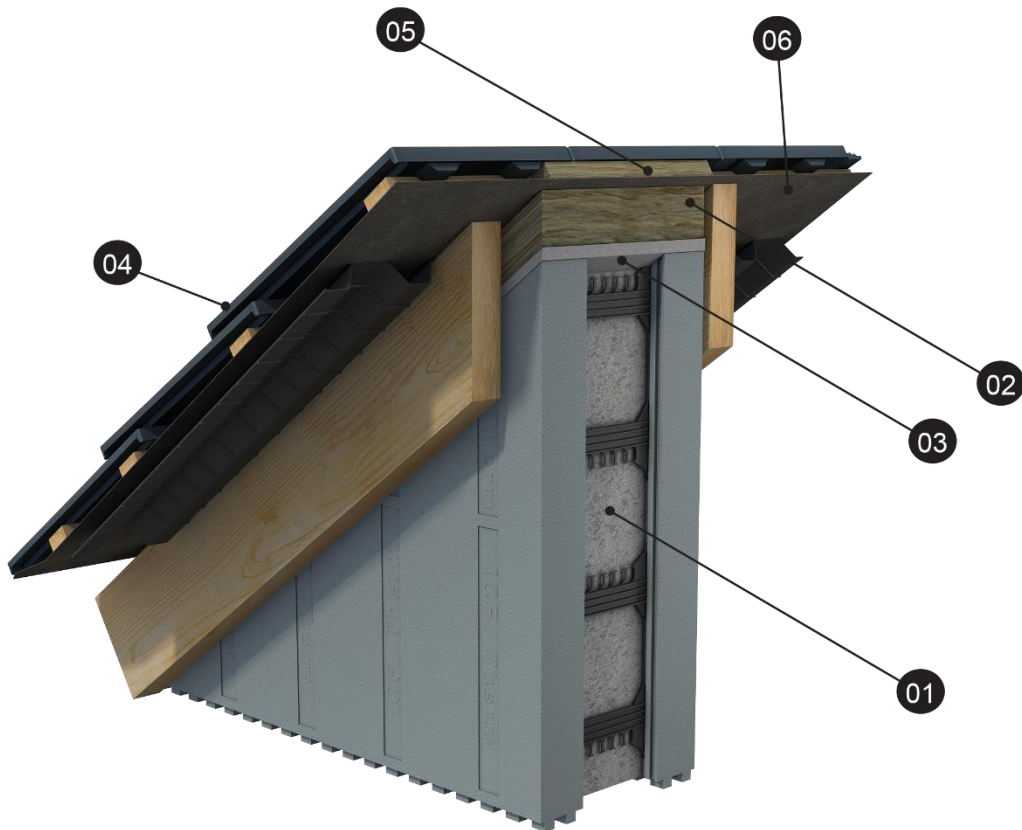

- 01. Concrete core
- 02. 100mm Mineral Wool Insulation fire stop packed between Calcium Sillicate board and roofing underlay.
- 03. 12.5mm non-combustable, fire-rated, calcium sillicate board installed on top of party wall.
- 04. Roof Finish.
- 05. Mineral wool insulation firestopping to be installed between roofing battens to underside of roof covering in accordance with TGD 8 volume 2 digram 10.

Where timber tiling battens are to be carried over the separating wall, they should be fully bedded in mortar or other suitable non-combustible fire stopping material for the full width of the wall.

- 06. Proprietary triple-ply roofing underlay.

Figure 20: Top of Compartment Wall to Roof with Fire Stop Detail In Non-Habitable Attic without Permanent Access

3.1 STRENGTH AND STABILITY

3.1.1 General

The Castleforms ICF Therm Wall System is intended for use where Architect's drawings are available and satisfy the Building Regulations – the Architect and Engineer design team of the Client are responsible for the architectural drawings and overall building design to comply with the Building Regulations.

Buildings constructed using the Castleforms ICF Therm Wall System shall be certified by a competent, chartered structural engineer, with experience in design of buildings and structures incorporating the Castleforms ICF Therm Wall System, as being in accordance with Part A of the Building Regulations.

3.1.2 Substructure and Superstructure

Structural assessment is site and project specific. In accordance with I.S. EN 1990^[16], a DSL2 (Design Supervision Level) should be employed to check the design in line with good practice.

Reinforcement for lintel load spans and spacings of anchor bolts for the Simpson Strong Tie Ledger System, or similar, must be designed by the client's structural engineer.

Where timber elements are used, they are designed in accordance with I.S. EN 1995-1-1^[21] and I.S. EN 1995-1-2^[20].

3.1.3 Loading

The loading is calculated based on I.S. EN 1990^[16] and I.S. EN 1991-1-1^[17]. The loading depends on usage of the building, client requirements and other project specific requirements.

The following self-weights apply to the Castleforms ICF Therm Wall thicknesses:

- 150mm concrete core wall: 3.8kN/m²
- 200mm concrete core wall: 5.1kN/m²

The designs for typical dwellings must include for both live and dead loads, wind loads and snow loads which can be established using the following standards:

- I.S. EN 1990^[16]
- I.S. EN 1991-1-1^[17]
- I.S. EN 1991-1-4^[19]

Design snow and wind loads must be based on guidance given in TGD to Part A of the Building Regulations.

Panel designs are based on the wind exposure map provided in the TGD to Part A of the Building Regulations. For very exposed sites on hills above

the general level of the surrounding terrain, the system can be specifically designed to withstand the unusually high wind loading. This is likely to involve the provision of additional ground anchorage and increased lateral bracing, both of which can be readily provided in the system.

3.1.4 Retained Earth

Differences in the final level of ground or floor slabs between one side of a wall and the other should not exceed four times the core thickness. Water ingress shall also be addressed in that case by the architect.

3.1.5 Stability

Stability in permanent and temporary condition shall be designed by the client's structural engineer including details of floor and roof tying-in. Refer to section 2.4.6 for stability during the construction of the system.

3.1.6 Impact Resistance

The Castleforms ICF Therm Wall System provides a robust system that has a high resistance to hard and soft body impacts likely to be associated with normal use situations.

If a render finish is applied to the ICF walls the chosen render system must be classed as Category I at a minimum.

3.2 STRUCTURAL FIRE SAFETY

The concrete structural elements of Castleforms ICF Therm have a Class 0 rating and are non-combustible as per TGD of Part B of the Building Regulations. Castleforms ICF Therm blocks are manufactured in accordance with I.S. EN 13163^[1] from flame-retardant EPS. The EPS has a Class E reaction to fire when measured in accordance with I.S. EN 15715 and classified in accordance with I.S. EN 13501-1.

The internal and external finishes of Castleforms ICF Therm walls also have a Class 0 'spread of flame' rating. Castleforms ICF Therm compartment wall with a 150mm concrete core has over 60 minutes fire performance.

Escape stairways constructed using the Castleforms ICF Therm Wall System must be lined with fire retardant linings.

The NSAI approved external render system must obtain a B-s1, d0 per I.S. EN 13501-1. In the case of the internal wall, as the design is for use of 12.5mm gypsum plasterboard slabs screwed to the webs of the polypropylene connectors, the internal walls have a Class 0 rating and are acceptable for all areas according to the general provisions of

Clause 2.1 of Section B2 of TGD to Part B of the Building Regulations, and Clause 2.4 of Section B7 of TGD Volume 2 to Part B of the Building Regulations.

3.2.1 Fire Barriers

Fire stopping shall be provided at all compartment floors and compartment walls as per drawings included in this certificate. The location of fire breaks should be specified by the Architect or Fire consultant on a project specific basis.

In general, for dwelling houses (purposes groups 1(a) and 1(b), according to TGD Volume 2 to Part B of the Building Regulations), the fire stopping is required vertically at the junction of external walls with a compartment wall. The insulation around the window and door openings is fire stopped by the external render. The location of fire breaks should be agreed with the architect.

When cavities are present in ICF wall build up the cavity barriers as per Clause 3.6.2 TGD Part B should be provided. No cavities will be present when plasterboard is screw fixed to ICF wall and there are no service voids.

External Wall/ Floor Junction – internal fire break

In case where a solid or open web timber joist floor is used as an intermediate floor, a fire stopping will need to be provided where cavities are present. Where the service void is created in the wall build-up, fire stopping shall be provided at the top of the void at floor level. Fire stopping can be achieved by a timber battens (min. 38mm thick), mineral wool or galvanised metal strip (minimum 1mm thick), combined or not with the use of insulation in the floor void which has a classification of A2 or better for buildings under 10m in height. A section of the inner ICF Therm form is removed allowing the timber batten to be directly fixed back to the concrete core.

External Wall/ Roof Junction – internal fire break

Where the service void is created in the wall build-up, fire stopping shall be provided at the top of the void. Fire stopping can be achieved by a combination of timber battens (min 38mm thick), and / or the use of insulation in the roof void which has a classification of A2 or better for buildings under 10m in height. A section of the inner ICF Therm form is removed allowing the timber batten to be directly fixed back to the concrete core.

External Wall/ Compartment Wall and Floor – external fire break (vertical and horizontal)

External vertical fire break shall be provided at the junction of external walls with every compartment wall. In addition, it is required to use fire breaks horizontally at the junction between external walls and every compartment floor.

External fire break materials should be continuous and unbroken. A galvanised metal strip with a

minimum 1mm thickness (weight 2.68kg/m²) can be used as an external fire break. The metal strip is inserted to the full depth of the ICF Therm form, as described in Section 3.3.4 of TGD to Part B of the Building Regulations, and Section 3.6.3 of TGD Volume 2 to Part B of the Building Regulations. Where walls are externally rendered additional strip of reinforcing mesh is applied over the fire break to strengthen the area. Glass wool is not suitable for use as a firestop.

As an alternative to the external fire break, a non-combustible mineral wool could be used as a fire break, typically installed in 100-200mm wide strips with minimum density of 120kg/m³. The outer ICF Therm form is removed and the mineral wool strip is adhesively bonded to the exposed concrete core substrate and mechanically fixed with stainless steel fixings at 300mm centres.

3.2.2 Toxicity

The system is non-toxic in normal conditions. In fire conditions, the polystyrene will begin to soften, to contract, and final melt above 200°C. The polystyrene used in the Castleforms ICF Therm Wall System is flame retarded.

3.2.3 Security of Fixings

Stainless steel mechanical fixings at 300mm ctrs are required where the mineral wool forms a fire stopping detail.

Plasterboard slabs are screw-fixed to the polypropylene connectors as an internal finish.

3.3 WEATHERTIGHTNESS

Externally the walls are protected by an approved render. A DPC/radon barrier is installed at ground level to prevent rising damp. A DPC is also used around window cills, and a double seal -window bead gasket and silicone- is used at window reveals. In the case of aluminium window cills, they shall be provided with stop ends. In the case of concrete sills, they shall project 75mm at each side of the window opening. Concrete sills shall be wrapped in DPC.

3.4 PENETRATIONS

To reduce radon, air and moisture ingress into buildings the following guidelines should be followed:

- Design for controlled movement of construction (see I.S. EN 1996-1-1);
- Ensure that all designed cavities are effectively closed to interior spaces;
- Design for grouping of services with effective gas seal of ground slab openings and penetrations.

3.5 ELECTRICAL AND PLUMBING SERVICES

The positioning and future access to all plumbing and electrical services should be carefully considered during the design phase of the construction.

Electrical installation should meet the requirements of I.S. 10101^[15]. The Castleforms ICF Therm Wall System shall not be placed in direct contact with electrical cables or hot water pipes (max temp 80°C). Conduits for cables and sockets shall be provided in accordance with I.S. 10101^[15].

3.7 LIMITING THERMAL BRIDGING

The linear thermal transmittance ' ψ ' (Psi) describes the heat loss associated with junctions and around openings. The certificate holder has carried out ψ -value calculations for a range of thermally bridged junctions.

' ψ ' (Psi) values of Table 6 can be used to calculate 'y' factor for DEAP building energy rating (BER) calculation on project by project case basis.

Where either of the above options are shown to be valid, or when the required values cannot be achieved, all relevant details should be recorded on the 'Certificate of Compliance' for that project for use in future BER calculations.

ψ -values for other junctions outside the scope of this certificate should be assessed by an NSAI approved thermal modeller in accordance with Appendix D of TGD to Part L of the Building Regulations.

3.8 DURABILITY AND MAINTENANCE

The structural core of the system should have a service life of not less than 60 years provided it is designed in accordance with Part A of Irish Building Regulations. The EPS formwork will have a similar service life provided it is protected from damage by the external and internal finishes of the wall construction.

The concrete in the wall panels is maintenance free. If a coloured render finish is used, the coloured rendering may discolour with time. A re-coating of the top coat may be necessary every 18 to 20 years to improve the appearance. The external sealants around window and door frames should be inspected periodically and replaced when necessary.

The render manufacturer is responsible for the design of the render to meet the durability requirements and exposure conditions. Render shall meet durability and exposure conditions as per S.R. 325^[33].

Any damage to the surface finish shall be repaired immediately and regular maintenance shall be undertaken as outlined in render manufacturer's specification.

Castleforms' EPS Characteristics		
Material Characteristics	EPS 150	Test Standard
Thermal Conductivity	0.031W/mK	EN 12667
Reaction to Fire	Class E	EN 15715
Compressive Strength σ_{10}	CS (10) 150	EN 826
Bending Strength	BS 200	EN 12089
Long Term Water Absorption by Total Immersion	WL(T)i 4.5%	EN 12087
Dimensional Stability	DS(N)5	EN 1603
Length	L2	EN 822
Width	W2	EN 822
Thickness	T1	EN 823
Flatness	P(5)	EN 825
Squareness	S (5)	EN 824

Table 2: Properties of EPS used in Castleforms ICF Therm Wall System

4.1 THERMAL PERFORMANCE

The thermal conductivity, λ value of the Castleforms ICF Therm wall is 0.031W/mK for the EPS, with allowance made for the cold bridging effect of the polypropylene connector. The calculated U-value for the Castleforms ICF Therm 335mm and 360mm wall can meet or exceed the required U-value of 0.18/m²K. Where the calculated U-value does not meet the relevant requirement of the Building Regulations, additional energy improvement measures such as internal drylining board may be used to meet the backstop elemental U-values outlined in TGD to Part L of the Building Regulations.

A sample U-value calculation results of Castleforms ICF Therm wall are given in Table 3, 4 & 5 of this Certificate. Calculations of the U-value for specific constructions should be carried out in accordance with I.S. EN ISO 6946.

4.2 CONDENSATION AND MOISTURE RESISTANCE

The Castleforms ICF Therm Wall System was subjected to an interstitial condensation risk analysis, assessing internal surface temperatures (fR_{si}). The assessment concluded that the risk of condensation is minimal and that no vapour barrier is required.

4.3 SOUND

Airbourne test carried out on the Castleforms ICF Therm Wall with 150mm concrete core gave a sound attenuation of 55 dB DnT,w which exceeds the requirements of TGD Part E of Building Regulations.

4.4 PRACTICABILITY

The practicability of construction and adequacy of site supervision arrangements were assessed and considered adequate. Castleforms System Design Manual and Installation Manual guidelines are provided by Castleforms for each project and these were reviewed and found to be satisfactory.

4.5 TESTS AND ASSESSMENTS WERE CARRIED OUT TO DETERMINE THE FOLLOWING

- Structural strength and stability
- Behaviour in fire
- Density
- Long term water absorption by diffusion
- Dimensional accuracy
- Compressive stress
- Bending strength
- Dimensional stability
- Resistance to airborne and impact sound transmission
- Thermal transmittance values

- Site erection controls

4.8 OTHER INVESTIGATIONS

- (i) Existing data on product properties in relation to fire and the effect on mechanical strength/stability and durability were assessed.
- (ii) The manufacturing process was examined including the methods adopted for quality control, and details were obtained of the quality and composition of the materials used.
- (iii) Site visits were conducted to assess the practicability of installation and the history of performance in use of the product.
- (iv) No failures of the product in use have been reported to NSAI Agrément.

U-value Calculation For 310 ICF Therm Block					
Layer	Description	% Bridged	Thickness [mm]	Thermal conductivity λ [W/m K]	Thermal resistance R [W/m ² K]
	Rse				0.040
1	Render (typical values)		7	1.00	0.007
2	Castleform Grey EPS		75	0.031	2.419
3a	Grey EPS	50	6	0.031	0.194
3b	Concrete	50	6	2.30	0.003
4	Reinforced Concrete		150	2.30	0.065
5a	Grey EPS	50	6	0.031	0.194
5b	Concrete	50	6	2.30	0.003
6	Castleform Grey EPS		75	0.031	2.419
7	Plasterboard TGD Part L		12.5	0.250	0.050
	Rsi				0.130
Ru Total =					5.324
RL Total =					<u>5.141</u>
R Average =					<u>5.232</u>
Correction term, ΔU =					<u>0.000</u>
Corrected U-Value (2DP) =					0.19 W/m ² K

Table 3: U-value Calculation for the 310mm ICF Therm Block Wall

U-value Calculation For 335 ICF Therm Block					
Layer	Description	% Bridged	Thickness [mm]	Thermal conductivity λ [W/m K]	Thermal resistance R [W/m ² K]
	Rse				0.040
1	Render (typical values)		7	1.00	0.007
2	Castleform Grey EPS		100	0.031	3.226
3a	Grey EPS	50	6	0.031	0.194
3b	Concrete	50	6	2.30	0.003
4	Reinforced Concrete		150	2.30	0.065
5a	Grey EPS	50	6	0.031	0.194
5b	Concrete	50	6	2.30	0.003
6	Castleform Grey EPS		75	0.031	2.419
7	Plasterboard TGD Part L		12.5	0.250	0.050
	Rsi				0.130
Ru Total =					6.131
RL Total =					<u>5.948</u>
R Average =					<u>6.039</u>
Correction term, ΔU =					<u>0.000</u>
Corrected U-Value (2DP) =					0.17 W/m ² K

Table 4: U-value Calculation for the 335mm ICF Therm Block Wall

U-value Calculation For 360 ICF Therm Block					
Layer	Description	% Bridged	Thickness [mm]	Thermal conductivity λ [W/m K]	Thermal resistance R [W/m ² K]
	Rse				0.040
1	Render (typical values)		7	1.00	0.007
2	Castleform Grey EPS		125	0.031	4.032
3a	Grey EPS	50	6	0.031	0.194
3b	Concrete	50	6	2.30	0.003
4	Reinforced Concrete		150	2.30	0.065
5a	Grey EPS	50	6	0.031	0.194
5b	Concrete	50	6	2.30	0.003
6	Castleform Grey EPS		75	0.031	2.419
7	Plasterboard TGD Part L		12.5	0.250	0.050
	Rsi				0.130
Ru Total =					6.937
RL Total =					<u>6.754</u>
R Average =					<u>6.846</u>
Correction term, ΔU =					<u>0.000</u>
Corrected U-Value (2DP) =					0.15 W/m ² K

Table 5: U-value Calculation for the 360mm ICF Therm Block Wall

Target linear thermal transmittance (ψ) for different types of junctions.		
Junction Description	Temperature Factor f_{Rsi} (Min = 0.75)	Castleforms Ψ -value (W/mK)
Strip Foundation Detail with Ground Bearing Slab	0.93	0.074
Castleforms' Raft Therm Foundation Detail	0.83	0.188
Typical Raft Foundation Detail	0.90	0.104
Eaves	0.88	0.047
Window Head with EPS closer	0.94	0.007
Window Jamb	0.92	0.013
Window Cill with EPS Cill Block	0.84	0.015
Window Cill	0.83	0.091
Window Reveal Detail With Timber Vertical Closer	0.84	0.028
Corner Normal	0.91	0.049
Corner Inverted	0.96	0.078
Separating Wall Through Ground Floor	0.83	0.240*
Precast Concrete Separating Floor within a Dwelling	0.88	0.115
Timber Intermediate Floor within a Dwelling	0.90	0.093
Door Threshold	0.77	0.067
ICF Separating Wall (plan)	0.95	0.105*
Psi value is for the whole junction. Half the value should be applied to each dwelling on either side of the junction (*). Flanking element U-values for walls, roof and floor thermal models above were based on $U_w = 0.17$ W/m ² k, $U_R = 0.12$ W/m ² k Modelled junction ψ -values above can be used in γ -value calculations.		

Table 6: Typical ψ -Value W/mK

5.1 National Standards Authority of Ireland ("NSAI") following consultation with NSAI Agrément has assessed the performance and method of installation of the product/process and the quality of the materials used in its manufacture and certifies the product/process to be fit for the use for which it is certified provided that it is manufactured, installed, used and maintained in accordance with the descriptions and specifications set out in this Certificate and in accordance with the manufacturer's instructions and usual trade practice. This Certificate shall remain valid for five years from date of latest revision so long as:

- (a) the specification of the product is unchanged.
- (b) the Building Regulations and any other regulation or standard applicable to the product/process, its use or installation remains unchanged.
- (c) the product continues to be assessed for the quality of its manufacture and marking by NSAI.
- (d) no new information becomes available which in the opinion of the NSAI, would preclude the granting of the Certificate.
- (e) the product or process continues to be manufactured, installed, used and maintained in accordance with the description, specifications and safety recommendations set out in this certificate.
- (f) the registration and/or surveillance fees due to NSAI Agrément are paid.

5.2 The NSAI Agrément mark and certification number may only be used on or in relation to product/processes in respect of which a valid Certificate exists. If the Certificate becomes invalid the Certificate holder must not use the NSAI Agrément mark and certification number and must remove them from the products already marked.

5.3 In granting Certification, the NSAI makes no representation as to;

- (a) the absence or presence of patent rights subsisting in the product/process; or
- (b) the legal right of the Certificate holder to market, install or maintain the product/process; or

(c) whether individual products have been manufactured or installed by the Certificate holder in accordance with the descriptions and specifications set out in this Certificate.

5.4 This Certificate does not comprise installation instructions and does not replace the manufacturer's directions or any professional or trade advice relating to use and installation which may be appropriate.

5.5 Any recommendations contained in this Certificate relating to the safe use of the certified product/process are preconditions to the validity of the Certificate. However, the NSAI does not certify that the manufacture or installation of the certified product or process in accordance with the descriptions and specifications set out in this Certificate will satisfy the requirements of the Safety, Health and Welfare at Work Act, or of any other current or future common law duty of care owed by the manufacturer or by the Certificate holder.

5.6 The NSAI is not responsible to any person or body for loss or damage including personal injury arising as a direct or indirect result of the use of this product or process.

5.7 Where reference is made in this Certificate to any Act of the Oireachtas, Regulation made thereunder, Statutory Instrument, Code of Practice, National Standards, manufacturer's instructions, or similar publication, it shall be construed as reference to such publication in the form in which it is in force at the date of this Certification.

NSAI Agrément

This Certificate No. **22/0431** is accordingly granted by the NSAI to **Castleforms Ltd** on behalf of NSAI Agrément.

Date of Issue: **3rd of June 2022**

Signed

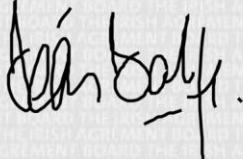

Seán Balfe
Director of NSAI Agrément

Readers may check that the status of this Certificate has not changed by contacting NSAI Agrément, NSAI, 1 Swift Square, Northwood, Santry, Dublin 9, Ireland. Telephone: (01) 807 3800. Fax: (01) 807 3842. www.n sai.ie

Revisions:

02 February 2023: Thermal modelling data, updates to Sections 3.2 and 3.8

Bibliography

- [1] I.S. EN 13163:2012+A2:2016 *Thermal insulation products for buildings – Factory made expanded polystyrene (EPS) products – Specification.*
- [2] I.S. EN 206:2013+A2:2021 *Concrete – Specification, performance, production and conformity.*
- [3] BS 4449:2005+A3:2016 *Steel for the reinforcement of concrete – Weldable reinforcing steel – Bar, coil and decoiled product – Specification.*
- [4] BS 4482:2005 *Steel wire for the reinforcement of concrete products – Specification.*
- [5] BS 4483:2005 *Steel fabric for the reinforcement of concrete – Specification.*
- [6] I.S. EN 10020:2000 *Definition and classification of grades of steel.*
- [7] I.S. EN 1992-1-1:2004 *Eurocode 2: Design of concrete structures – Part 1-1: General rules and rules for buildings.*
- [8] S.R. 82:2017 *Slating and tiling – Code of practice.*
- [9] BS 8004:2015+A1:2020 *Code of practice for foundations.*
- [10] I.S. EN 1992-3:2006 *Eurocode 2: Design of concrete structures – Part 3: Liquid retaining and containment structures.*
- [11] BS 8102:2009 *Code of practice for protection of below ground structures against water from the ground.*
- [12] SR 21:2014 *Guidance on the use of I.S. EN 13242 aggregates for unbound and hydraulically bound materials for use in civil engineering work and road construction.*
- [13] I.S. EN 13242:2002 *Aggregates for unbound and hydraulically bound materials for use in civil engineering work and road construction.*
- [14] I.S. 888:2016 *Code of practice for the procurement and use of unbound granular fill hardcore material for use under concrete floors.*
- [15] I.S. 10101:2020+AC1:2020 *National rules for electrical installations.*
- [16] I.S. EN 1990:2014 *Eurocode 0 – Basis of structural design.*
- [17] I.S. EN 1991-1-1:2002 *Eurocode 1: Actions on structures – Part 1-1: General actions – Densities, self-weight, imposed loads for buildings.*
- [18] I.S. EN 1991-1-7:2006 *Eurocode 1: Actions on structures – Part 1-7: General actions – Accidental actions.*
- [19] I.S. EN 1991-1-4:2005 *Eurocode 1: Actions on structures – Part 1-4: General actions – Wind actions.*
- [20] I.S. EN 1995-1-2:2005 *Eurocode 5: Design of timber structures – Part 1-2: General – Structural fire design.*
- [21] I.S. EN 1995-1-1:2005 *Eurocode 5: Design of timber structures – Part 1-1: General – Common rules and rules for buildings.*
- [22] I.S. EN 826:2013 *Thermal insulating products for building applications – Determination of compression behaviour.*
- [23] I.S. EN 1992-1-2:2004+AC:2008+A1:2019 *Eurocode 2: Design of concrete structures – Part 1-2: General rules – Structural fire design.*
- [24] EAD 040083-00-0404:2019 *External thermal insulation composite systems (ETICS) with renderings.*
- [25] I.S. EN 15715:2009 *Thermal insulation products – Instructions for mounting and fixing for reaction to fire testing – Factory made products.*

- [26] I.S. EN 13501-1:2007 *Fire classification of construction products and building elements – Classification using data from reaction to fire tests.*
- [27] I.S. EN 1996-1-1:2005+A1:2012 *Eurocode 6 – Design of masonry structures – Part 1-1: General rules for reinforced and unreinforced masonry structures.*
- [28] BRE IP 1/06 *Assessing the effects of thermal bridging at junctions and around openings.*
- [29] BRE BR 497 *Conventions for calculating linear thermal transmittance and temperature factors.*
- [30] I.S. EN ISO 13370:2017 *Thermal performance of buildings – Heat transfer via the ground – Calculation methods.*
- [31] EAD 340309-00-0305:2019 *Non load-bearing permanent shuttering kits/systems based on hollow blocks or panels of insulating materials and sometimes concrete*
- [32] I.S. EN 10080:2005 *Steel for the reinforcement of concrete – Weldable reinforcing steel – General*
- [33] S.R. 325 *Recommendations for the design of masonry structures in Ireland to Eurocode 6*